



DOOSAN FORKLIFTS DIESEL PNEUMATIC 13,500 lb. to 20,000 lb. Capacity

D60S-9 | D70S-9 | D80S-9 | D90S-9

9-SERIES



PRODUCT FEATURES OVERVIEW

SUPERB ERGONOMICS

- Seat-Side Hydraulic Levers & Control Switches
- Low Effort Foot Pedal
- High Comfort Full Suspension Seat
- Telescopic and Tilting Steering Column
- Increased Headroom
- Recessed Tilt Cylinders
- Full Color LCD Display
- Convenience Tray
- Ultra Quiet High Vis Cab (Option)
- Full Automatic Temperature Control System (Cab Option)

MODERN SAFETY FEATURES

- Guardian Stability System (GSS)
- Operator Sensing System (OSS)
- Superior Visibility through these improvements:
 - Optimized Mast Design
 - Lowered Dashboard
 - Redesigned Overhead Guard (Bar Type)
 - Redesigned Cabin Layout
- Easy Entry/Exit
- Electronic Parking Brake (EPB)
- Hi-Vis Orange Seat Belt
- Programmable Speed Limit (Forward & Reverse)
- Auto Deceleration
- Large Rearview Mirror
- Panoramic Mirror
- Siren & Microphone (Option)
- Rear View Camera and Proximity Sensor (Option)

TIRELESS PRODUCTIVITY & RELIABILITY

- Powerful 3.4L Doosan Diesel Engines
 - (55kW D60/70 or 81kW All Models)
- Quiet Running Tier-4 Final Diesel Engine
- Three Performance Modes (ECO/STD/High)
- Enhanced Cooling Capacity
- IP67 Rated Dust/Waterproof Connectors
- Full Floating Type Cabin
- 3-Speed Auto-Shift Transmission
- Electronic Inching
- LED Combination Lamps
- Weight Scale (Hydraulic/Load Cell) - Option
- Manual Tilt w/ Optional Power Tilt (OHG/Cabin)
- Vehicle Control Unit (VCU)
- Shift ProTek Hot Shift Protection
- Mast Angle Indicator



MEET THE NEW DOOSAN 9 SERIES DIESEL LIFT TRUCKS!

Building upon Doosan's tradition of delivering reliable, powerful performance, these trucks also offer the best possible value. Doosan provides increased productivity, improved comfort, and some of the lowest overall costs of ownership of any competitive forklifts on the market.



SMART VCU FUNCTIONS (VEHICLE CONTROL UNIT)

- Guardian Stability System
- Operator Sensing System
- Mast Interlock
- Inching Pedal
- Seatbelt Alarm
- Empty Seat Alarm
- Water in Fuel Alarm
- Parking Brake Control
- Shift ProTek (Forward/Reverse) Shift Control
- Autoshift
- Speed Limit
- Mast Angle Indicator
- Weight Scale
- Auto Tilt Fork Leveling
- Multi-performance Mode Indicator
- On Demand Hydraulic (Idle-Up RPMs)
- Digital Display Functions
- Planned Maintenance Reminder

** List includes both standard and optional features*

LOWER TOTAL COST OF OWNERSHIP (TCO)

- Oil Cooled Disc Brakes (OCDB)
- Extended Planned Maintenance Intervals
 - Transmission Oil - Now 2,000 hrs.
 - Drive Axle Oil - Now 1,000 hrs.
 - Engine Oil - Now 1,000 hrs.
- 50° Wide Opening Engine Compartment
- Dual Element Air Cleaner
- Tool Free Access Panels
- Easy Diagnostics
- Quick Accessibility to Maintenance Points
- Automatic Service Notification
- Low Maintenance Engine
- Lower Total Cost of Ownership (TCO)

OPTIONAL FEATURES

- Modular Cabin
- Newly Designed Hi-Vis Cabin
- Superior Climate Control, 2 in 1 Air Conditioner
- Tankless Air Compressor
- Industry-specific Application Packages
 - Anti-Dust Package
 - Anti-Corrosion Package
 - Foundry Package

SUPERB ERGONOMICS FORM & FUNCTION



NEWLY DESIGNED FULL CABIN (OPTION)

The Doosan cabin provides the operator additional protection against harsher environments and the ergonomic lay-out improves productivity at the same time. Sealed cabin eliminates outside dust, and dual filter locations quickly purify cabin air.



DECREASED NOISE LEVEL

High quality sound-absorbing and sound insulation materials are applied to the entire cockpit. Connections to the exterior are well sealed and the thick fitted floor mat all combine to ensure a best-in-class quiet interior space.

The specially designed ergonomic operator compartment keeps the operator in complete control, improving productivity and reducing stress and fatigue.

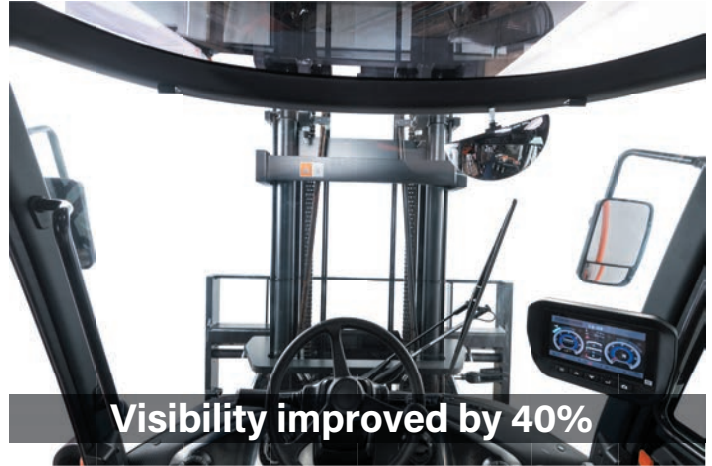

EXCELLENT OPERATOR VISIBILITY

Modern curved glass cabin offers improved visibility, which provides better operator awareness while improving efficiency and safety. With an upper section reinforced with high-rigidity polycarbonate, the field of vision is greatly expanded ensuring maximum productivity and safety.



CLEAR, BRIGHT 7" MULTI-FUNCTION DISPLAY PANEL

The bright 7" multi-function display provides excellent visibility of system status and settings. Features such as PIN code settings, speed limit settings, rear view camera, weight scale, and consumables replacement cycles can all be monitored within the display.

BEST-IN-CLASS OPERATOR COMFORT



FULLY ADJUSTABLE OPERATOR SPACE

The steering column, suspension seat, armrest, and headrest are all adjustable to accommodate the individual preferences of each operator.

CENTRALIZED SWITCHES

All operation switches are arranged in a single place, enhancing operator access. Additionally, a new keypad greatly adds to convenience. A power jack and USB port are provided as standard features.



COMFORTABLE 2-IN-1 AIR CONDITIONING SYSTEM

This system offers integrated control of heating, cooling and ventilation. Dual cabin air filters assure the operator that dust and dirty air will be cleaned quickly and efficiently.



POWERFUL PERFORMANCE

DOOSAN'S POWERFUL 3.4L CLEAN DIESEL ENGINES

- Bosch 1,800 bar common rail fuel injectors for reliable performance and excellent fuel economy
- ULCF Technology assures improved combustion through optimization of the piston bowl and injector nozzles
- Higher performance and less fuel consumption
- Conforms to Stage5/Tier4 final regulations
 - Automatic DPF regeneration
 - PM reduced by 40%
 - NOx reduced by 98%
- Increased engine torque in the low-to-medium range
 - 55kw - 395fp @ 2,300 rpm (DMO3V engine)
 - 81kw - 339 fp @ 2,300 rpm (DMO3P engine)



ELECTRONICALLY CONTROLLED 3-SPEED AUTO-SHIFT TRANSMISSION

A control valve mounted on top of the transmission precisely modulates clutch oil pressure for smooth forward and reverse directional changes.

- A quality product produced by ZF - a brand trusted worldwide
- Fuel economy improves while driving long distances or working long hours
- Optimized power matching of the engine with the transmission
- Excellent engine responsiveness and powerful performance
- Efficient maintenance through the self-diagnosis system



STRONG AND DURABLE DRIVE AXLE

Doosan's drive axle design is one of the most substantially built in the industry. Combined with Doosan's industry leading Oil Cooled Disc Brakes, both drive axle and disc brakes offer long service life, with minimal maintenance costs.

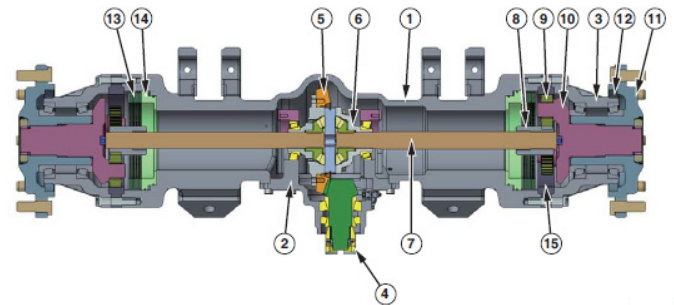

- | | | |
|-------------------|-------------------|------------------|
| 1. Axle Housing | 6. Differential | 11. Hub |
| 2. Carrier Base | 7. Axle Shaft | 12. Oil Seal |
| 3. Hub Housing | 8. Sun Gear | 13. Brake Discs |
| 4. U-joint Flange | 9. Planetary Gear | 14. Brake Piston |
| 5. Bevel Gear Set | 10. Carrier Shaft | 15. Ring Gear |

LOWER TOTAL COST OF OWNERSHIP (TCO)

- Maintenance-free valve clearance
- Auto-tensioner belt drive system
- Fewer planned maintenance intervals
- Self-diagnostics system for effective servicing



OUTSTANDING PRODUCTIVITY

PRE-PROGRAMMED PERFORMANCE MODES

Multi-Performance Mode allows operators to change parameters to meet application demands, while still delivering robust performance and excellent fuel efficiency.

- 'E' ECO Mode - Designed for fuel economy
- 'S' Standard Mode - For normal output
- 'H' High Performance Mode - Increases the power output of the truck for tough work applications



INTEGRATED COOLING SYSTEM

The combination of a large capacity radiator and the structural design of the counterweight maximizes airflow and enhances heat dissipation. This new configuration improves the durability of the truck, particularly in challenging applications.

OIL COOLED DISC BRAKES (OCDB) 5-YEAR, 10,000 Hr. WARRANTY

- Eliminate costly brake jobs and save thousands of dollars over the lifetime of the truck
- Brake discs operate in oil, reduce heat and limit wear
- Increased braking surface with superior stopping power
- More easily serviced in the field vs traditional brakes
- Sealed system for maximum protection against contamination

DUAL ELEMENT CYCLONE AIR CLEANER

The efficient dual air cleaner protects the engine from contamination, prolongs the life of the engine and extends service intervals. Air intake on the overhead guard helps draw fresh, clean air into the engine.

IP67 RATED CONNECTORS

Doosan's 9 Series bring a new level of outdoor protection with IP67 Rated electrical connectors. These trucks are extremely durable in various weather conditions.

AUTO THROTTLE UP

Automatically increases lift power (engine rpm) when sensors detect a load increase.

13,500 lb. to 20,000 lb. Capacity

WORKING CONVENIENCE

- Auto-Tilt leveling (Optional)
- Auto-Throttle Up
- Display mast angle, vehicle gradient & tire position

TRANSMISSION EMBEDDED PARK BRAKE

- Built-in parking brake in transmission
- Parking brake is released by parking switch
- No parking lever needed
- Smart Braking System automatically engages when the ignition is switched off

NEWLY DESIGNED INCHING PEDAL

By eliminating the inching cable and routing the inching brakes through the TCU (Transmission Control Unit), operators have a much more sensitive inching system, requiring much less effort.

INCREASED VISIBILITY THROUGH MAST

The 9 Series diesel forklifts hydraulic hoses and mast chains are neatly arranged for wide front visibility, crucial for effective operation and safety.



ADVANCED SAFETY FEATURES

The 9 Series Diesel forklifts have advanced safety systems in place to protect your most valuable asset, your people. With our GSS and OSS systems safeguarding your operators, with Doosan, you have peace of mind.



GUARDIAN STABILITY SYSTEM (GSS)

The Guardian Stability System (GSS) will dynamically protect the operator and the load to reduce risks.

Features Include:

- Auto speed control when sensors indicate a sharp turn
- Decreased travel speed (50%) when mast is raised above primary stage
- Forward tilt reduced to 2° when mast is raised above primary stage
- Alarm sounds when mast is raised above primary stage with mast tilted more than 2°

REAR DETECTOR SYSTEM (OPTIONAL)

Safety alarm is triggered when a pedestrian or object comes within the sensor range, enhancing operator awareness.

AUTOMATIC DECELERATION

Should the operators foot slip from the accelerator pedal while driving, the truck automatically decelerates quickly and safely, reducing braking distance by up to 50%.

FRONT AND REAR VIEW CAMERA W/ MONITOR (OPTIONAL)

Optional front and rear view cameras keep blind spots to a minimum, providing another level of safety and peace of mind.



OPERATOR SENSING SYSTEM - (OSS)

Should the operator leave the seat, the OSS automatically prohibits operations such as:

- Truck movement forward or reverse
- Mast lift, lower and tilt functions
- Seat belt warning light reminding the operator to fasten seatbelt

MODERN SAFETY FEATURES

- Guardian Stability System (GSS)
- Operator Sensing System (OSS)
- Visibility Improved by 40%
 - Optimized Mast Design
 - Lower Dashboard
 - Redesigned Cabin Layout
- Safe Entry & Exit System
- Electronic Parking Brake (EPB)
- Shift ProTek Hot Shift Protection
- Safety Orange Seat Belt
- Seat Belt Safety Switch
- Travel Speed Controls (Forward & Reverse)
- Auto Deceleration
- Large Rearview Mirror
- Rear View Mirrors, Left & Right
- Panoramic Mirror
- Front and Rear View Camera (Option)
- Siren & Microphone (Option)
- Weight Scale (Hydraulic/Load Cell) Option
- 4th Lever Interlocking for Clamp Attachment. (Option)
- Seat Belt Interlock (Option)

TANKLESS AIR COMPRESSOR (OPTIONAL)

- The new, economical and miniaturized air compressor makes it easier to manage and clean equipment.
- Primary applications: grease filling, air filter cleaning, radiator cleaning, cooling fan cleaning, OPC cleaning, engine compartment cleaning and tire pressure replenishment.

(Grease gun and air filler purchased separately)



VERSATILE FLEXIBLE

ANTI-DUST PACKAGE

This package prevents overheating due to dust buildup on the forklift.

Preferred option for tough applications such as: Lumber & Stone, Steel, Ceramic Tile, Solid Fertilizer, Cotton and Recycling.

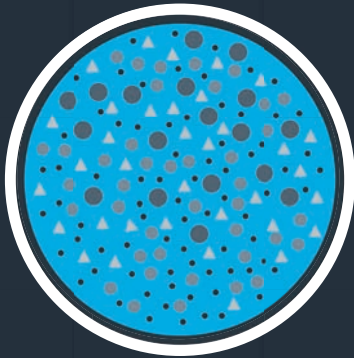

FOUNDRY PACKAGE

Recommended for customers who mainly operate trucks in high temperature environments such as: Foundry (Iron, Aluminum, or Nonferrous Metals), Casting or Forging and Rolling.



ANTI CORROSION PACKAGE

Designed for high-temp and high humidity environments. Prevents corrosion due to wet or corrosive environments such as Fisheries, Ports and Chemical Storage.



PERFORMS WELL IN VARIOUS APPLICATIONS



Building Materials



Chemicals

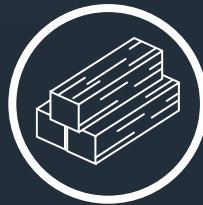

Lumber & Wood



Recycling



Foundries



Manufacturing

MAINTAINANCE MADE EASY

EASY TO DIAGNOSE

Diagnostics are simple and quick needing only a cable and laptop. Less time searching for error codes, more time working, Doosan 9 Series Diesels.



EASY TO ACCESS

- Effortless engine hood opening
- Cabin or OHG opens to a full 60°
- Power tilt (option)
- Hood opening increased to 50° for ease of routine maintenance



EASY TO SERVICE

- Easy access to all routinely serviced items
- CAN bus communication
- Central junction box for fuses and relays



LOWER COST OF OWNERSHIP

FEWER SERVICE INTERVALS

- Engine oil change: was 500 hr. - now 1,000 hr.
- Transmission oil change: was 1,000 hr. - now 2,000 hr.
- Drive axle oil change: was 500 hr. - now 1,000 hr.
- Fuel filter replacement was 500 hr. - now 1,000 hr.
- Total savings on 5 year routine maintenance = **\$1,995**



STRONGER MAJOR COMPONENTS

- Larger king pins and tapered roller bearings for a stronger axle
- Angled rollers are stronger against side forces
- Tapered roller bearings have an inner race, eliminating wear on the king pin
- Total savings on 5 year steer components = **\$2,640**



OIL COOLED DISC BRAKES (OCDB)

- Exclusive 5 year/10,000 hr. warranty
- Enclosed system, practically no maintenance required
- Multi-Disc, OCDBs provide smooth, consistent stopping power
- Keeps brakes cool in any application
- Total savings on 5 year brake repairs = **\$3,670**



D70S-9 Series Total Cost of Ownership Assessment			SAVINGS  \$6,505*
5 Year Repair/Maintenance	Competitor	Doosan	
Planned Maintenance Services	\$2,106	\$1,911	
Steer Axle Services & Repair	\$2,640	\$0	
Brake Services & Repair	\$4,415	\$745	
Total	\$9,161	\$2,656	

OPERATING THE 9 SERIES FOR 5 YEARS CAN SAVE YOU UP TO 71% (OVER \$6,500) VERSUS COMPETITIVE MODELS!

ADDITIONAL SAVINGS

- Increased fuel economy, Eco mode can save you up to 1 liter of fuel per hour.
- Longer-lasting LED lamps
- Maintenance free valve clearance

The purchase and ownership of a Doosan forklift includes access to a highly knowledgeable and responsive customer support team.

As a Doosan customer, your authorized factory-trained dealer will provide the best after-sales service and support, all backed by Doosan's own customer service center. In addition, Doosan's excellent parts fill rate will ensure minimal downtime.

The Doosan network starts with your local dealer and extends to a national team of qualified and experienced personnel, ready to support a wide array of material handling needs.

STANDARD FEATURES AND OPTIONAL EXTRAS

SAFETY		STANDARD	OPTION
Guardian Stability System (GSS)		0	
Mast Interlock - Tilt, Lift and Lower		0	
Operator Sensing System (OSS)		0	
Anti-Cinch Orange Seat Belt		0	
Travel Speed Control		0	
Back-up Alarm		0	
Rear Grab Bar w/Horn		0	
Auto Deceleration		0	
Interlocking Seat Belt			0
Interlocking 4th Lever			0
Spark Arrester			0
Front & Rear View Cameras			0
Proximity Sensors			0
PRODUCTIVITY		STANDARD	OPTION
Electric Controlled TCI (Turbo Charged Intercooler) Doosan Engines		0	
Low Pressure Pedal (Accelerator, Brake and Inching)		0	
Inching Pedal		0	
LED Lighting		0	
High Visibility Mast		0	
3 Performance Modes (ECO/STD/HIGH)		0	
Vehicle Control Unit (VCU)		0	
Transmission Control Unit (TCU)		0	
Weight Scale			0
Autotilt Leveling			0
ERGONOMICS		STANDARD	OPTION
Adjustable Steering Column		0	
Integrated Display		0	
Easy Entry & Exit		0	
Full Cabin with Heater or Air Conditioner			0
Premium Seat: Suspension, Heat, Head Restraint			0
Powered Cabin Tilt			0
DURABILITY		STANDARD	OPTION
Electronic Control Units (ECU) Cover		0	
IP67 Water Resistant Connectors		0	
Dual Element Air Cleaner		0	
Full Floating Driveaxle (with OCDB)		0	
Autoshift Controller		0	
Tilt Cylinder Cover		0	
Heavy Duty Cooling		0	
Radiator Screen			0
Vented Side Panel			0
Engine Pre-Cleaner			0
SERVICEABILITY		STANDARD	OPTION
CAN bus Communication System		0	
Electric Tilttable Cabin		0	
Ease of Service		0	
- Integrated Electric Components in the Junction Box (Relays and Fuses)		0	
- Wide Opening Cabin (60°)		0	
- Wide Engine Cover Opening Range		0	
ENVIRONMENT		STANDARD	OPTION
Emission Regulation (Tier5 and Stage 5)		0	
Ultra Low Particulate Combustion (ULPC) System (with DOC)		0	
ISO 9001/ISO 14001		0	

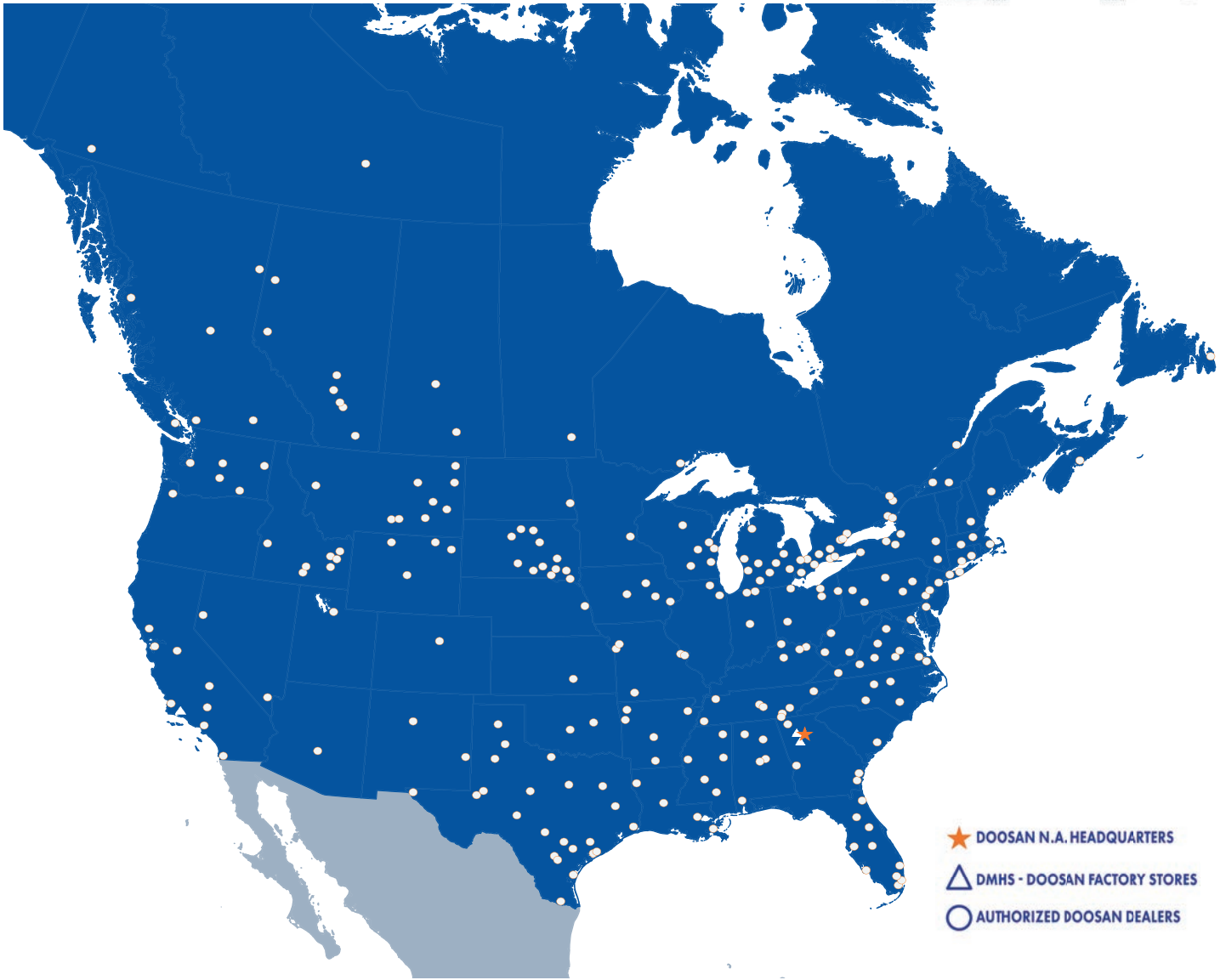

Doosan's North American Dealer Network

Doosan provides superior material handling solutions to address your specific needs. From energy efficient electrics to robust internal combustion forklifts, Doosan is your full-line provider.



Doosan Industrial Vehicle America
 2475 Mill Center Parkway, Suite #400
 Buford, GA 30518
 P) 678-745-2200
www.DoosanLift.com

PSCD70S-9V1

