

www.doosanlift.com



Walkie Stacker

3,300lb(1,500kg) Capacity

BWS17S-7



Walkie Reach Stacker

3,300lb(1,500kg) Capacity

BWP17S-7



About Doosan

Values that drive our future growth

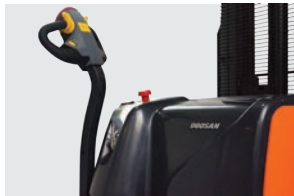

The Doosan Way is a unique set of corporate values and philosophy that has guided our growth. It is a systematic management philosophy for sustaining Doosan and raising our future competitive edge. The Doosan Way consists of two key parts: the Doosan Credo and a distinctive business system.

The Doosan Credo

A resolute vision, the Doosan Credo unifies our employees worldwide, providing the direction in which we march together towards the future. Our shared aspiration is to be a global leader that provides world-class products and services that employees, customers, shareholders, and other stakeholders can trust and take pride in. The Doosan Credo places the highest importance on people, integrity, innovation, and delivering value to our customers and partners.

The Efficient Business System

Our core business system is comprised of human resources, strategy execution, and financial management. Through this system, we implement our “2G Strategy” a manifestation of our conviction that our business can only grow through the growth of our people. It binds and systematizes our strategy with our people, multiplying business results. The Doosan business system supports the performance-oriented culture of Doosan and paves the way for continuous growth and development.

Cultivating People

Doosan’s leadership course, Doosan Leadership Institute (DLI), strengthens job performance while teaching trainees the Doosan Way. The DLI is a space for learning and growth that realizes and continuously develops our philosophy of “People are the Future.” The purpose of the DLI is to create an organization that develops global leaders.

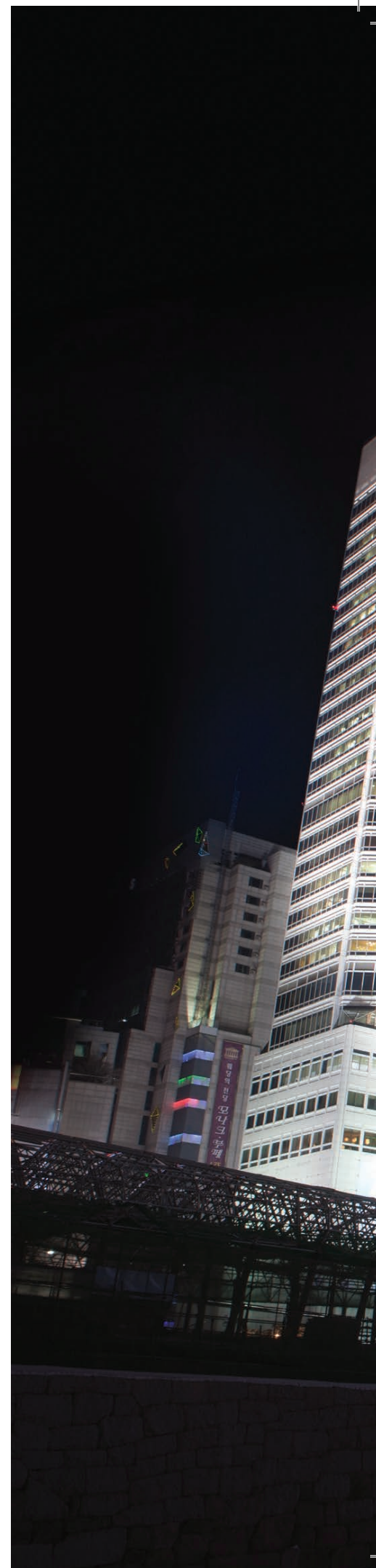

Doosan Industrial Vehicle

Major global player in the infrastructure support business with a proud heritage

With a proud history dating back to 1937, when we first started out as Chosun Machinery, Doosan Industrial Vehicle has grown into Korea's largest machinery manufacturer, playing a leading role in the development of the industry in Korea.

Today, we are a global enterprise. We operate large-scale plants and sales subsidiaries both at home and overseas and maintain an operational network that spans continents.

Committed To Innovation

We remain committed to the advancement of new technologies and development of talented individuals, positioning us to respond effectively to the rapid changes taking place in the 21st century. Our mission is to strengthen our global position and become the industry leader well into the future.

Committed To Our Customers

We are committed to our customers, providing superior products and excellent services to go with them.

Our Promise

Doosan Industrial Vehicle will be the partner you can count on, always putting our commitment to you first.

Award-Winning Machines

Doosan currently holds a number of export, design & safety awards, including four Forklift Truck Association awards for Design Excellence.



BWS17S-7 WALKIE STACKER

Economy, First Class

Doosan's BWS17S-7 Walkie Stacker can move, lift, stack and store products in your warehouse without a large investment.

- A 24-volt AC drive system is smooth, powerful, efficient and requires minimal maintenance.
- The ergonomic control handle has a low speed/brake override switch for maneuverability in tight areas.
- Adjustable outriggers make it easy to handle different sized loads.
- Standard deep cycle batteries and a built-in charger keep products on the move.
- A standard storage tray provides a convenient place to store job related items.

The Doosan BWS17S-7 Walkie Stacker is a highly maneuverable, powerful, and versatile stacker.



Small Turning Radius

The Doosan Stacker series design provides a significantly tighter turning radius than typical counterbalanced lift trucks.

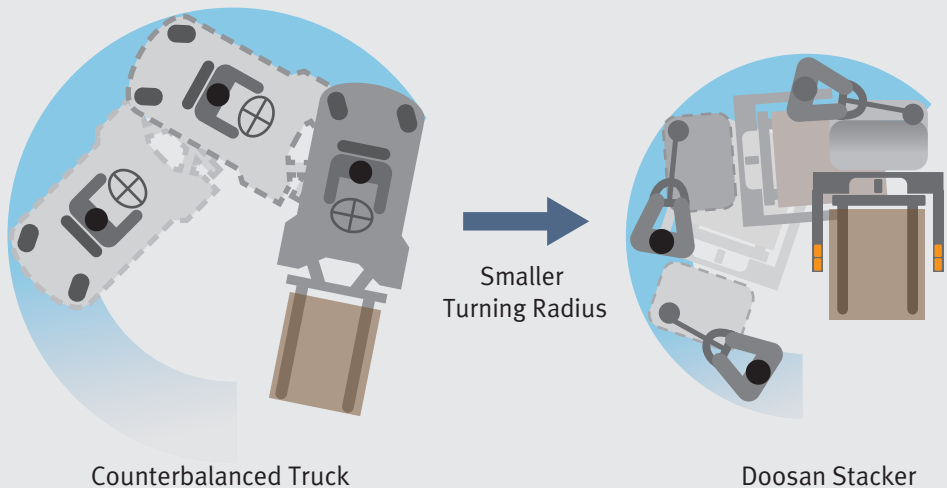

BWP17S-7 WALKIE REACH STACKER



Ergonomic Handle

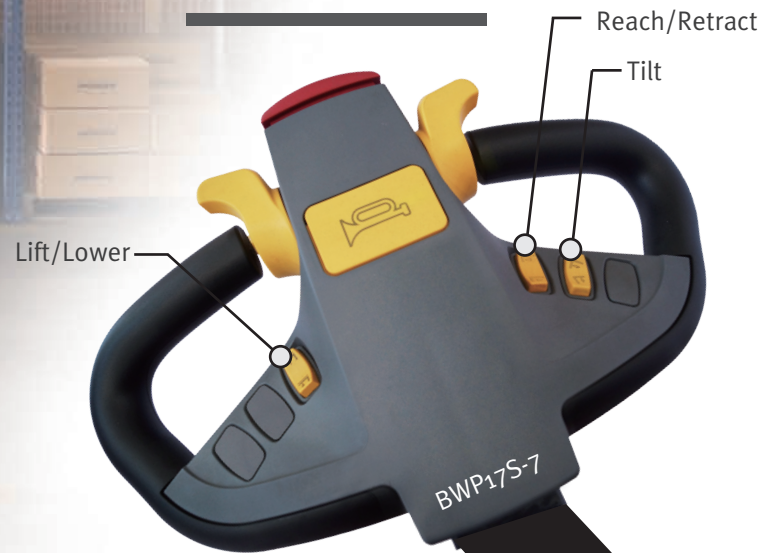

The Versatile Performer

Doosan's BWP17S-7 Walkie Reach Stacker is equipped to handle many jobs. Whether it's working in narrow aisles or moving freight on the dock, this walkie truck can be used to supplement full size forklifts in many ways.

- The 156" triple mast can stack loads high while maintaining a low collapsed height for clearance under doorways or overhead obstructions.
- The industrial sized battery compartment gives you longer run times necessary for completing the job.
- Standard battery rollers and dual side gates allow replacement batteries to be easily removed and installed.
- The standard tilting fork carriage helps speed removal and replacement of loads in the rack and provides exact positioning.
- The ergonomic control handle has all the hydraulic functions at your fingertips, not out of reach on the chassis.
- An adjustable spring loaded caster helps stabilize loads when lifted and when making turns.
- The Curtis Controller provides precise travel control necessary to maneuver in tight narrow aisles.

The Doosan BWP17S-7 Walkie Reach Stacker can perform the tasks of larger and more expensive equipment at a fraction of the cost. You will be impressed with its versatility.

GET **MORE** FOR YOUR MONEY

Walkie Stacker

BWS

Hour Meter / BDI

BWS17S-7 comes standard with an Hour Meter/Battery Discharge Indicator to keep track of hours used and reserve battery power at a glance.



Low Speed / Brake Override Switch

Allows creep speed operation with handle in the upright position. Increases ability to maneuver in tight spaces.

Ergonomic Handle

Reduces operator fatigue.

Three Mast Heights

106", 130" (STD), and 145"
Versatility to meet your application.

CAN Bus Technology

This reduces the number of connections and potential for problems making the system less complicated and more reliable.

Roll-Out Battery Tray

Allows for easy maintenance, removal and replacement.

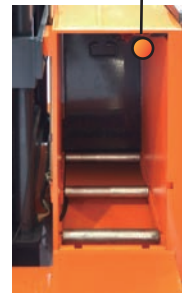

Poly Drive Tire

Provides longer tire life and has lower energy consumption versus a rubber tire.

Adjustable Spring Loaded Caster

Helps stabilize loads when lifted and when making turns.



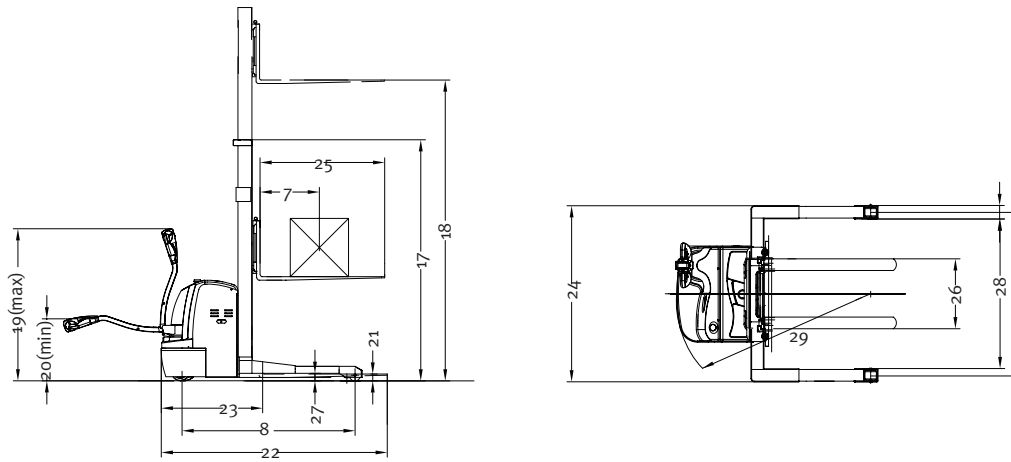

Specification

Characteristics		
1	Model	BWS17S-7
2	Power type	Electric
3	Operator type	Walkie Stacker
4	Load capacity	lbs (kg) 3300 (1500)
5	Tire type (drive/load/caster)	D/L/C Polyurethane
6	Wheels (x = driven)	F/R 1 x, 1/2
7	Load center	in (mm) 24 (600)
8	Wheelbase	in (mm) 57.4 (1460)
Weight		
9	Total service weight (without battery) 130" (3300) mast	lbs (kg) 2163 (980)
10	Axle loading: loaded (front/rear)	lbs (kg) 2582/3200 (1170/1450)
11	Axle loading: unloaded (front/rear)	lbs (kg) 1037/331 (470/150)
12	Battery weight	lbs (kg) 441 (200)
Chassis		
13	Tire compound	Polyurethane
14	Drive tire dimensions	in (mm) 10 x 3 (250 x 70)
15	Load wheel dimensions	in (mm) 3.23 x 6.81 (82 x 173)
16	Caster wheel dimensions	in (mm) 5 x 2.4 (127 x 57)
Dimensions		
17	Mast height lowered: 130" (3300) mast	in (mm) 90 (2295) STD
18	Mast lift height	in (mm) 130 (3300) STD
19	Control handle height (max)	in (mm) 51.18 (1300)
20	Control handle height (min)	in (mm) 26.38 (670)
21	Lowered fork height	in (mm) 2 (50)
22	Overall length	in (mm) 76.96 (1955)
23	Length to face of forks	in (mm) 34.56 (878)
24	Overall width - adjustable base legs (min/max I.D.).	in (mm) 44.96 / 60.31 (1142 - 1532)
25	Fork dimensions	in (mm) 1.6 x 4 x 42 (40 x 100 x 1070)
26	Overall fork width (min/max)	in (mm) 35.43 - 51.18 (900 - 1300)
27	Ground clearance	in (mm) 1.10 (28)
28	Adjustable base legs (min/max I.D.)	in (mm) 35 - 51 (889 - 1295)
Performance		
29	Turning radius	in (mm) 65.6 (1640)
30	Service brake	Electro-Magnetic
31	Travel speed: loaded/unloaded	mph (kph) 3.6/3.7 (5.8/6)
32	Lift speed: loaded/unloaded	fps (mps) .52 (.16) / .82 (.25)
33	Lowering speed: loaded/unloaded	fps (mps) 1.2 (.37) / 1.1 (.34)
34	Battery voltage nominal capacity: K5	V/Ah 24/200
35	Battery compartment: rollout tray size (775 x 252 x 300)	in 30.51 x 9.94 x 11.81
36	Control type	24 AC

* Specifications and dimensions of vehicles may change without notice for quality improvement, and images shown in this catalogue may differ with actual ones.

GET **MORE** FOR YOUR MONEY

Walkie Reach Stacker **BWP**

82"/156" Triple Mast

Allows for higher lift heights while retaining a low collapsed height.

Hour Meter / Battery Discharge Indicator

Keeps operator informed of battery reserve capacity and maintenance intervals.



Low Speed / Brake Override Switch

Allows creep speed operation with handle in the upright position. Increases ability to maneuver in tight spaces.

Ergonomic Handle

Reduces operator fatigue.

Pantograph Reach Mechanism

Reaches the overall length of the truck providing a tighter turning radius over counterbalanced stackers.

Tilting Fork Carriage

Gives the correct fork angle for productive load handling.

Plexi-glass Mast Guard

Ultimate in safety and visibility.

Sizable Battery Compartment

13" battery compartment for use with an industrial battery.

Roll-Out Battery Tray

Allows for easy maintenance, removal and replacement.



Large Base Legs

Provides the stability needed for higher lift heights.

Adjustable Spring Loaded Caster

Helps to stabilize the unit when lifting loads.



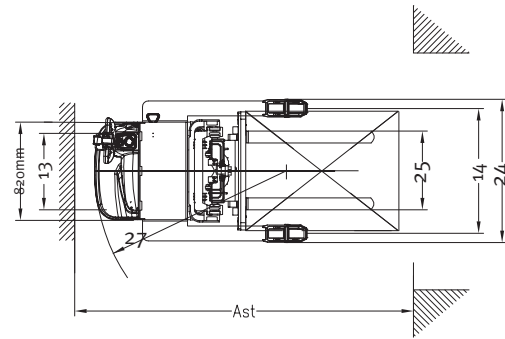
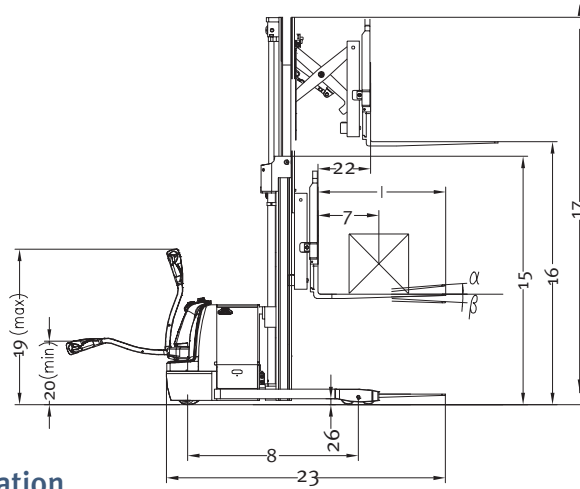

Specification

Characteristics		
1 Model		BWP17S-7
2 Power type		Electric
3 Operator type		Walkie Stacker
4 Load capacity	lbs (kg)	3300 (1500)
5 Tire type (drive/load/caster)	D/L/C	Polyurethane
6 Wheels (x = driven)	F/R	1 x, 1/4
7 Load center	in (mm)	19.7 (500)
8 Wheelbase	in (mm)	56.9 (1445)
Weight		
9 Total service weight (without battery) 130" (3300) mast	lbs (kg)	5357 (2430)
Chassis		
10 Tire compound	lbs (kg)	Polyurethane
11 Tire size (front)	in (mm)	10 x 3 (250 x 70)
12 Tire size (rear)	in (mm)	5 x 3.2, 6 x 2.4 (125 x 82, 150 x 60)
13 Tread (front)	in (mm)	20.5 (520)
14 Tread (rear)	in (mm)	47.6 (1210)
Dimensions		
15 Mast height lowered	in (mm)	84.4 (2145)
16 Mast lift height	in (mm)	156 (3962)
17 Mast height extended	in (mm)	211.6 (5375)
18 Tilting angle	$\alpha/\beta(^{\circ})$	2/5
19 Control handle height (max)	in (mm)	51.18 (1300)
20 Control handle height (min)	in (mm)	26.38 (670)
21 Fork dimensions	in (mm)	1.6 x 4 x 42 (40 x 100 x 1070)
22 Reach stroke	in (mm)	19.7 (500)
23 Overall length	in (mm)	92.1 (2340)
24 Overall width	in (mm)	53.5 (1360)
25 Overall fork width (min/max)	in (mm)	7.9 - 29.5 (200 - 750)
26 Ground clearance	in (mm)	1.4 (35)
Performance		
27 Turning radius	Wa in (mm)	65.0 (1650)
28 Service brake		Electro-Magnetic
29 Travel speed: loaded/unloaded	mph (kph)	3.23/3.48 (5.2/5.6)
30 Lift speed: loaded/unloaded	fps (mps)	.07 / .10 (.12/.17)
31 Lowering speed: loaded/unloaded	fps (mps)	.19 / .10 (.3/ .17)
32 Battery voltage nominal capacity: K5	V/Ah	24/560
33 Battery compartment size	in (mm)	30.7 x 13.1 x 24.4 (780 x 335 x 620)

* Specifications and dimensions of vehicles may change without notice for quality improvement, and images shown in this catalogue may differ with actual ones.

Complementary Products

Doosan manufactures a wide range of quality products utilizing the latest technology and safety features.

Doosan's warehouse equipment provides excellent mobility and increased return on your investment over larger more expensive units.

Combined with our Electric, LPG, and Diesel powered forklifts, Doosan's warehouse products will bring efficiency to your operation, increasing your overall productivity.

SITDOWN FORKLIFTS



4-wheel LPG cushion tire
3,000 - 6,500lb capacity



4-wheel, LPG/Diesel pneumatic tire
3,000 - 36,500lb capacity



3-wheel, Electric cushion tire
2,500 - 4,000lb capacity



4-wheel, Electric cushion tire
3,000 - 6,500lb capacity













REACH TRUCKS



Pantograph Reach Truck
3,500 - 4,000lb capacity



Walkie Stacker

Application Chart						
Transporting	 Hand Pallet Truck HPT	 Walkie Pallet Truck BW	 Rider Pallet Truck BWR	 Tugger BWT	 Center Control Rider BWC	 Electric Counterbalanced Truck 3-wheel Cushion 4-wheel Cushion
		 Walkie Stacker BWS	 Walkie Reach Stacker BWP	 Reach Truck BRP		
Storage / Stacking						
Personnel Transport				 Stock Chaser BSC	 Personnel Carrier BUV	 Burden Carrier BBC

WAREHOUSE EQUIPMENT



Walkie Reach Stacker



Hand Pallet Truck
5,500lb capacity



Walkie Pallet Truck
4,500lb capacity



Rider Pallet Truck
6,500lb capacity



Center Control Rider
6,500lb capacity



Tugger
10,000lb towing capacity



Burden Carrier
4,400 - 5,500lb capacity



Personnel Carrier
600lb capacity



Stock Chaser
1,000lb capacity



Doosan Corporation Industrial Vehicle
 Seoul Office
 22/F, Doosan Tower, 18-12, Euljiro-6Ga,
 Jung-Gu, Seoul, South Korea
 Web site : www.doosan-iv.com

Doosan Industrial Vehicle America Corp.
 2475 Mill Center Parkway Suite 400
 Buford, GA 30518 US
 T: 888-323-9661
 website: www.doosanlift.com

AUTHORIZED DEALER