

Construction Equipment

DOOSAN

DL420-2

Powered by **Innovation**

Certain specification(s) are based on engineering calculations and are not actual measurements. Specification(s) are provided for comparison purposes only and are subject to change without notice. Specification(s) for your individual Doosan equipment will vary based on normal variations in design, manufacturing, operating conditions, and other factors. Pictures of Doosan units may show other than standard equipment.

DOOSAN

Hyundai Doosan Infracore

489 Injung-ro, Dong-gu, Incheon, South Korea
<http://global.doosanequipment.com>

DIPBE-00-2207

Hyundai Doosan Infracore is an affiliate of Hyundai Heavy Industries Group.
The Doosan trademark, **DOOSAN**, is used under license from Doosan Corporation.

Powered by **Innovation**



DL420-2

FEARLESS NEW LEADER FOR ROUGH WORK

SAVAGE BUT REFINED

- DL420-2 stays true to its root, outclass power and outstanding productivity, but with advanced features. Unmistakably bold new look with aggressive profile, bright LED lamp and Doosan brand.

ENDURING TOUGH, LAST ONE STANDING

- The advanced ZF wet drive axle and improved differential gear process increased gear flexural strength, enhancing the reliability and extending its lifespan.

FIERCE POWER, EXTREME CAPABILITY

- Engine combines exceptional power 226 kW output and high torque at low revs enables to precisely deliver the stable working speed.
- German ZF automatic transmission boasts stable performance, high reliability, a low failure rate and conveniently agile operation.
- With superior lift height and diversified bucket options DL420-2 provides increased loading capacity to handle more works.

INNOVATIVE CENTER OF CONTROL

- Newly designed cabin is spacious and provides wider view and enhanced safety, with low noise & vibration levels DL420-2's functional and refined in-and-out design delivers you comfort and total control.

OVERWHELMING PERFORMANCE

FULL AUTO TRANSMISSION

The front four and rear three transmissions are manufactured by ZF in Germany. It is with clutch shut off function for faster reaction during loading and lifting operations.

WET DRIVE AXLE AND LSD (LIMITED SLIP DIFFERENTIAL)

The ZF wet drive axle from Germany ensures stable and safe braking that is not affected by external factors. It has brake discs with long service life.

The front and rear axles are fitted with limited-slip differentials as standard. This automatically ensures the maximum tractive effort and easy driving over soft and slippery ground. Also ensures efficient power distribution and high travel speeds in load and carry.



ENGINE (WP12G310E302)

The perfect blend of efficiency and power. Weichai engine delivers superior performance with excellent fuel efficiency and long service life. It combines exceptional power 226 kW output and high torque at low revs. Engine matching technology perfectly harmonized with the hydraulic system and provides strong power and lower fuel consumption.

EASY MAINTENANCE



EASY APPROACH

Both sides of the hood can be opened to the side. Making daily oil inspection and maintenance works quicker and more convenient.



CONCENTRATED HYDRAULIC PORTS

Ports are concentrated in one place so that the operator can conveniently check the main pressure, steering pressure, and braking, lifting, unloading and shift pressure.



CONCENTRATED LUBRICATION

As the lubrication point of each pinshaft is exposed, it can be lubricated from the outside of the machine.

TRANSMISSION OIL INLET

As the transmission oil inlet is placed on one side of the body, oil can be injected easily.



EVER LASTING SOLIDITY

COOLING PERFORMANCE

The patented cooling system offers a guarantee for continuous and uninterrupted work under high temperatures.

DURABILITY TEST

All vital components should pass extensive and stringent standard durability test.

REINFORCED PINS

Where workload are most severe, diameter of 6 pins is thicker than competitors by 5 ~ 10 mm.

SOLID FRAME STRUCTURE

The box-shaped structure of the rear frame side plates, the enhanced frame strength makes it easy to meet the challenge posed by harsh working conditions.



LED LAMP

Existing front lamp has been upgraded to LED and totally eight more lights have been added. Six additional LED lights on the front and two more on the back. New additional working lamp contributes to enhanced safety through improved illumination. It secures operator's visibility by preventing the shadow.

REAR WIPER ON ROOF

The wiper along with rear work lamp secures better rear visibility. It enables smooth work even on rainy days.

SUNVISOR

Sunvisor is equipped on cabin to protect operator from the sunlight.

EXCLUSIVE IN AND OUT COMFORT

UPGRADED CABIN

The newly reformed cabin advanced with additional convenient facilities for operator comfort.

ERGONOMICALLY DESIGNED PEDAL

Electronic pedal which is also applied on global wheel loader models reduces fatigue of operator.

DELUXE SEAT

High back, deep-seated position, dual armrests and multi-level spring shock absorption guarantee a comfortable operation.

MOLDING FLOOR MAT

DL420-2 is fitted with standard floor mat, adopting high quality material.

AIR CONDITIONING

The high performance of air conditioning system provides an air flow which is adjusted and electronically controlled according to the conditions.

REAR VIEW CAMERA (OPTIONAL)

The safety of people and equipment is ensured by increasing the rear view using the rear camera and LCD monitor.

CONTROL HANDLE

Various options such as single handle, double handle, FNR handle, etc. satisfy the various demands of customers hanks to various functions, easy operation, and excellent fine movement.

TECHNICAL SPECIFICATION

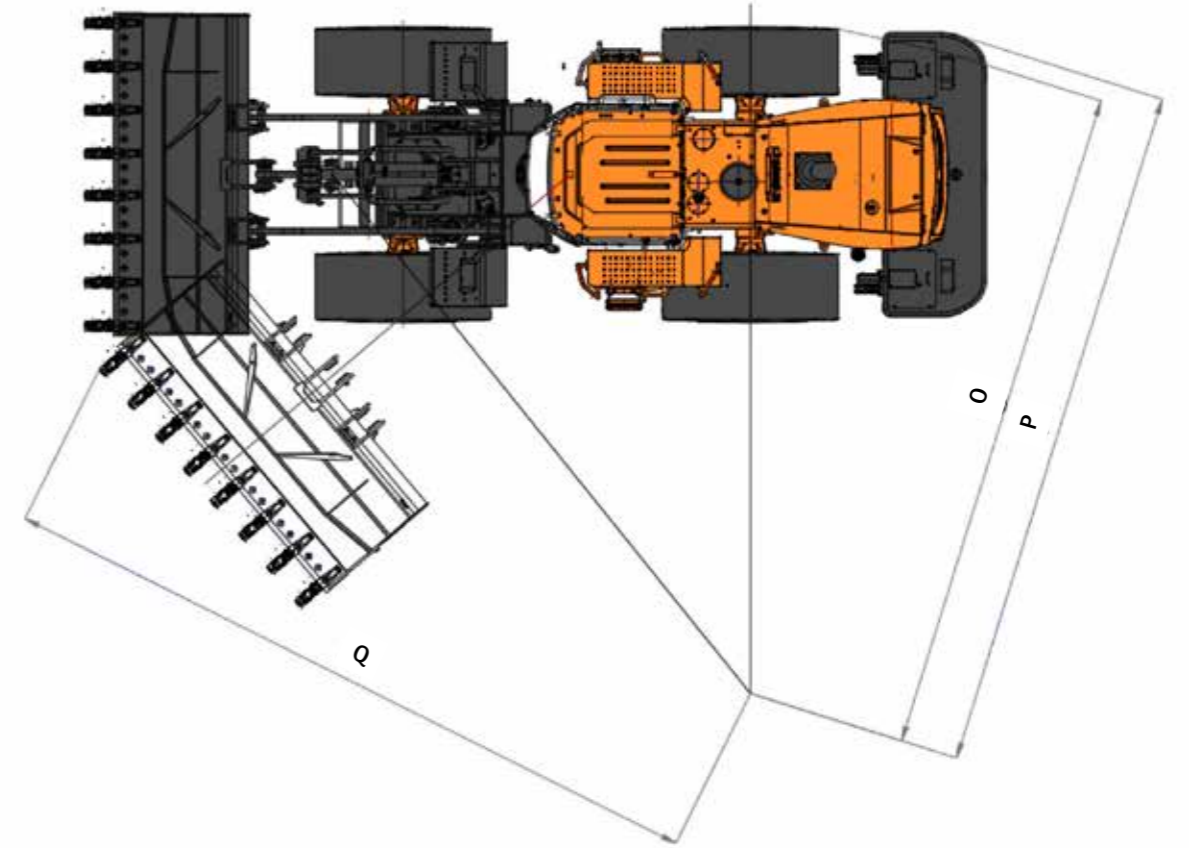

ENGINE

Model	Weichai WP12G310E302 (TIER 3)
Rated Power (SAE J1995 Gross)	226 kW @ 2,100 rpm
Max. Torque (SAE J1995 Gross)	1,450 N.m @ 1,300~1,500 rpm
Number of cylinders/bores/strokes	6 / 126 mm / 155 mm
Displacement	11,596 cc
Fuel Consumption	160 g/ps.hr

TRAVEL SYSTEM

TransmissionType	4 Speed, W/O Lock-up, Power-shift, Countershaft, Engine Direct Mounted with Adapter
Torque Converter Stall Ratio/Size	3.089 / 370 mm
Axle Type	fully floating planetary-type hub drive fixed mounting LSD (30%)
Brake Type	Wet disc

TRAVEL SPEEDS

Travel Speed (Forward 1/2/3/4)	8.0 / 13.4 / 27.4 / 37.5 km/h
Travel Speed (Reverse 1/2/3)	8.0 / 13.3 / 25.3 km/h
Front Speed (Raise/Dump/Lower)	6.3 / 1.2 / 3.9 sec

GENERAL SPECIFICATIONS

Operating Weight	24.1 ton
Bucket Capacity (SAE HEAPED)	4.3 m ³
Payload	8.0 ton
Static Tipping Load (straight)	18,200 kg
System Pressure (Work/Steer)	200/185 kg/cm ²
Sound Level in CAB (2000/14/EC)	79.9 dB (A)
External Sound Power Level (2000/14/EC)	111.6 dB (A)
Fuel Tank Capacity	385 L
Tire Size	26.5-25-24 PR

HYDRAULIC SYSTEM

Main Pump Type	Fixed displacement gear pump
Main Pump Displacement	111 cc/rev
Max. Flow Rate	229 l/min

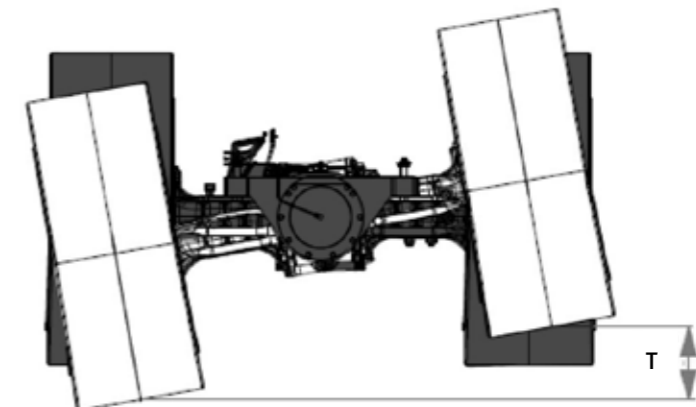
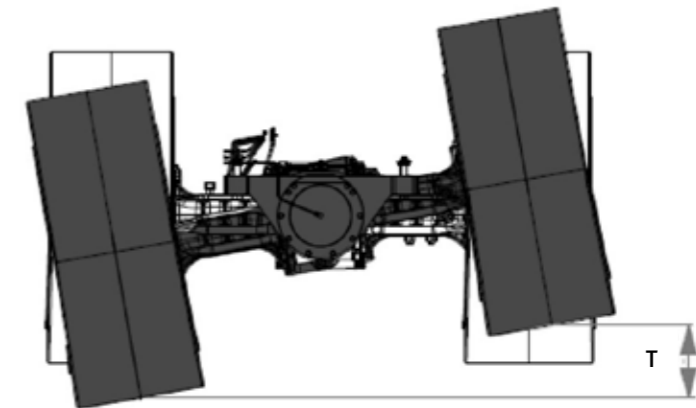

DIMENSIONS & WORKING RANGE

LOADER TYPE		General purpose									
Arm		STANDARD					HIGH LIFT				
Bucket		Teeth	Cutting Edge	Teeth	Light Material	Light Material	Teeth	Cutting Edge	Light Material	Teeth	
Configuration	Unit	STANDARD					OPTION 1		OPTION 2	OPTION 3	
Capacity heaped ISO/SAE	m ³	4.3	4.5	4.8	5.7	6.8	4.3	4.5	5.7	4.8	
Operating weight	kg	24,100	24,240	24,270	23,990	24,620	24,230	24,370	24,120	24,540	
Overall length	A	mm	9,160	8,948	9,214	9,088	9,243	9,520	9,308	9,393	9,574
Overall width	B	mm	3,200	-	-	-	-	3,200	-	3,470	3,300
Overall Height	C	mm	3,700	-	-	-	-	3,700	-	3,700	3,700
Ground Clearance	G	mm	495	-	-	-	-	495	-	495	495
Wheel Base	E	mm	3,550	-	-	-	-	3,550	-	3,550	3,550
Tread		mm	2,300	-	-	-	-	2,300	-	2,300	2,300
Gradeability	%(°)	49 (26)									
Bucket width	D	mm	3,200	3,200	3,300	3,470	3,670	3,200	3,300	3,470	3,300
Breakout force	kN		210	210	202	186	168	202	202	186	202
Static tipping load (straight)	kg		18,200	18,200	-	-	-	16,200	-	-	-
Static tipping load (at full turn)	kg		16,000	16,000	-	-	-	14,000	-	-	-
Dump height (at 45°) ¹⁾ (at fully raised)	H(H")	mm	3,026	3,180	2,988	3,112	3,006	3,380	3,532	3,467	3,340
Dump reach (at 45°) ¹⁾ (at fully raised)	I(I")	mm	1,446	1,301	1,485	1,450	1,561	1,484	1,338	1,489	1,521
Dump height (at max. dump) ¹⁾		mm	645	832	597	701	565	655	841	710	597
Dump reach (at max. dump) (at max. reach) ¹⁾		mm	1,890	1,789	1,912	1,841	1,915	2,195	2,095	2,147	1,912
Digging depth		mm	108	111	102	128	128	69	88	69	95
Height at bucket pivot point	J	mm	4,458	4,458	4,458	4,458	4,458	4,808	4,808	4,808	4,808
Max. tilt angle at carry position	K	deg	47	47	47.1	45.4	45.3	49	48.9	47.8	49
Max. tilt angle at fully raised	M	deg	60	59.7	59.7	60	60	60	60	60	60
Max. tilt angle on ground		deg	42	42.7	42	42.3	42.5	44	42.9	42.7	42.9
Max. tilt angle at max. reach		deg	58.3	58.3	58.3	58.3	64.5	57.2	57.2	57.1	57.2
Max. dump angle at max. reach		deg	61.2	61.2	61.2	61.2	63.6	60.1	60.1	62.8	60.1
Max. dump angle at fully raised	L	deg	45	45	45	45	45	45	45	45	45
External radius at bucket edge	Q	mm	7,138	-	-	-	-	-	-	7,383	-
Turning Radius at out tire edge	O	mm	6,570	-	-	-	-	6,570	-	6,570	6,570
Ground Clearance at 12° oscillation	T	mm	480	480	480	480	480	480	480	480	480
Rear Axle to Counter weight	S	mm	2,410	2,410	2,410	2,410	2,410	2,410	2,410	2,410	2,410
Overall length without bucket	R	mm	7,445	7,445	7,445	7,445	7,445	7,800	7,800	7,800	7,800

1) Measured to the tip of the bucket teeth

